

Dimension: 84 × 58 × 34mm

**Features:**

- Universal AC input range
- Small volume, low weight, high efficiency
- Protections : short circuit/over load/over voltage/over temp
- Cooling by free air convection
- LED indicator for power on
- 100% full load burn-in test
- 2 Years warranty



**SPECIFICATION**

Model		MS-35-5	MS-35-12	MS-35-15	MS-35-24
Output	DC voltage	5V	12V	15V	24V
	Voltage tolerance	± 1%	± 1%	± 1%	± 1%
	Rated current	5A	3A	2.4A	1.5A
	Current range	0 ~ 5A	0 ~ 3A	0 ~ 2.4A	0 ~ 1.5A
	Rated power	25W	36W	36W	36W
	Ripple&noise	80mVp-p	120mVp-p	120mVp-p	120mVp-p
	DC voltage ADJ. range	-9% ~ +10%	± 10%	± 10%	± 10%
Setup, rise, hold up time		800ms,20ms,24ms/230VAC.			
Input	Voltage range	90 ~ 264VAC 47 ~ 63Hz, 135 ~ 373VDC			
	AC current	0.75A/115VAC 0.45/230VAC			
	Efficiency	78%	81%	82%	83%
	Inrush current	Cold start30A/230VAC			
	leakage current	< 0.5mA/240VAC			
Protection	Overload	Rated output power115% ~ 135%Start overload protection Protection type: hiccup mode, auto-recovery after fault condition is removed			
	Over voltage	Rated output power145% ~ 170% Protection type: hiccup mode, auto-recovery after fault condition is removed			
	Over temperature	When temperature of transistor inner node is over 150°C,Start over temp protection Protection type: hiccup mode, auto-recovery after temperature become normal			
Environment	Working temp, humidity	-10°C ~ +60°C;20% ~ 90%RH(Please refer to “derating curve” )			
	Storage temp, humidity	-20°C ~ +85°C;10% ~ 95%RH Non-condensing			
	Withstand vibration	10 ~ 500Hz, 2G 10min./1Cycle, Period for 60min, Each axes			
Safety	Withstand voltage	I/P-O/P: 1.5KVAC I/P-FG: 1.5KVAC O/P-FG: 0.5KVAC			
	Isolation resistance	I/P-O/P: I/P-FG,O/P-FG: 100M Ohms/500VDC			
Fit standard	Safety standard	Fit UL1012			
	EMC Standard	Fit EN55022, CLASSA			
Others	Dimension	0.17kg 84*58*34 ( L*W*H )			
	Weight	0.18kg/100pcs/19kg/0.035m³/1.24CUFT			
	MTBF	380K hrs min. MIL-HDBK-217F(25°C)			

Note: 1. All parameters NOT specially mentioned are measured at 230VAC input, rated load and 25°C of ambient temperature.  
 2. Ripple & noise are measured at 20MHz of bandwidth by using a 12" twisted pair-wire terminated with a 0.1uf & 47uf parallel capacitor.  
 3. Tolerance : includes set up tolerance, line regulation and load regulation.

Mechanical specification

Unit:mm

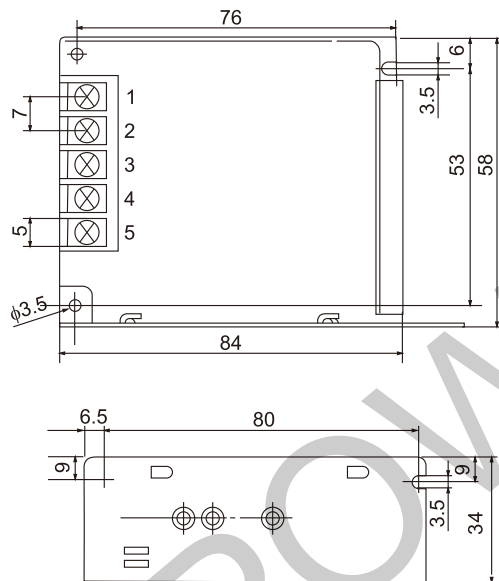

Terminal Pin No.Assignment

Pin No.	Assignment	Pin No.	Assignment
1	AC/L	4	DC OUTPUT -V
2	AC/N	5	DC OUTPUT +V
3	FG $\perp$		

Block diagram

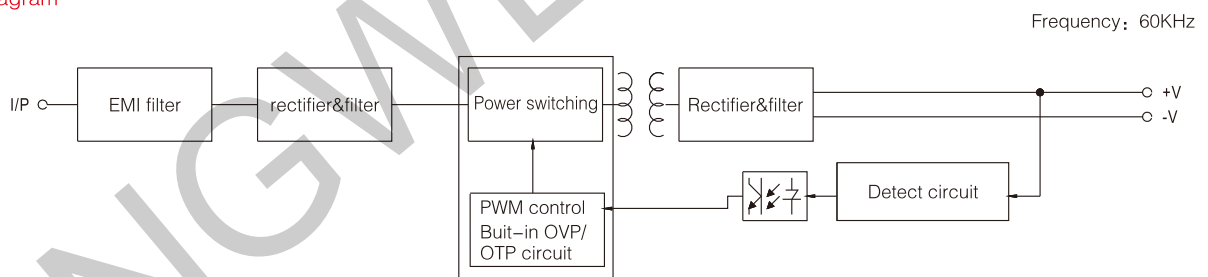

Derating curve

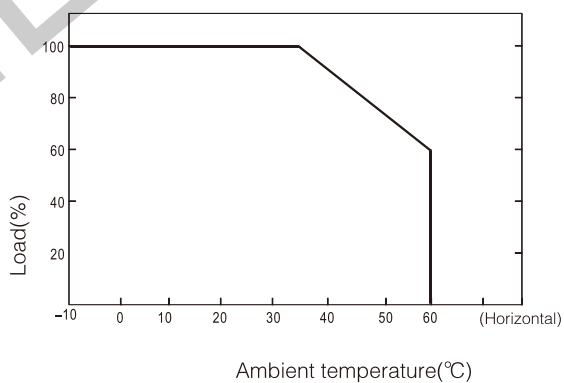

Static characteristic

